

Digital Humanities

Lecture 3

March 3

2025

Mario Verdicchio



**WE HAVE ENCODING
BECAUSE COMPUTERS
ARE DIGITAL**



**WE HAVE ENCODING
BECAUSE COMPUTERS
HAPPEN TO BE DIGITAL**

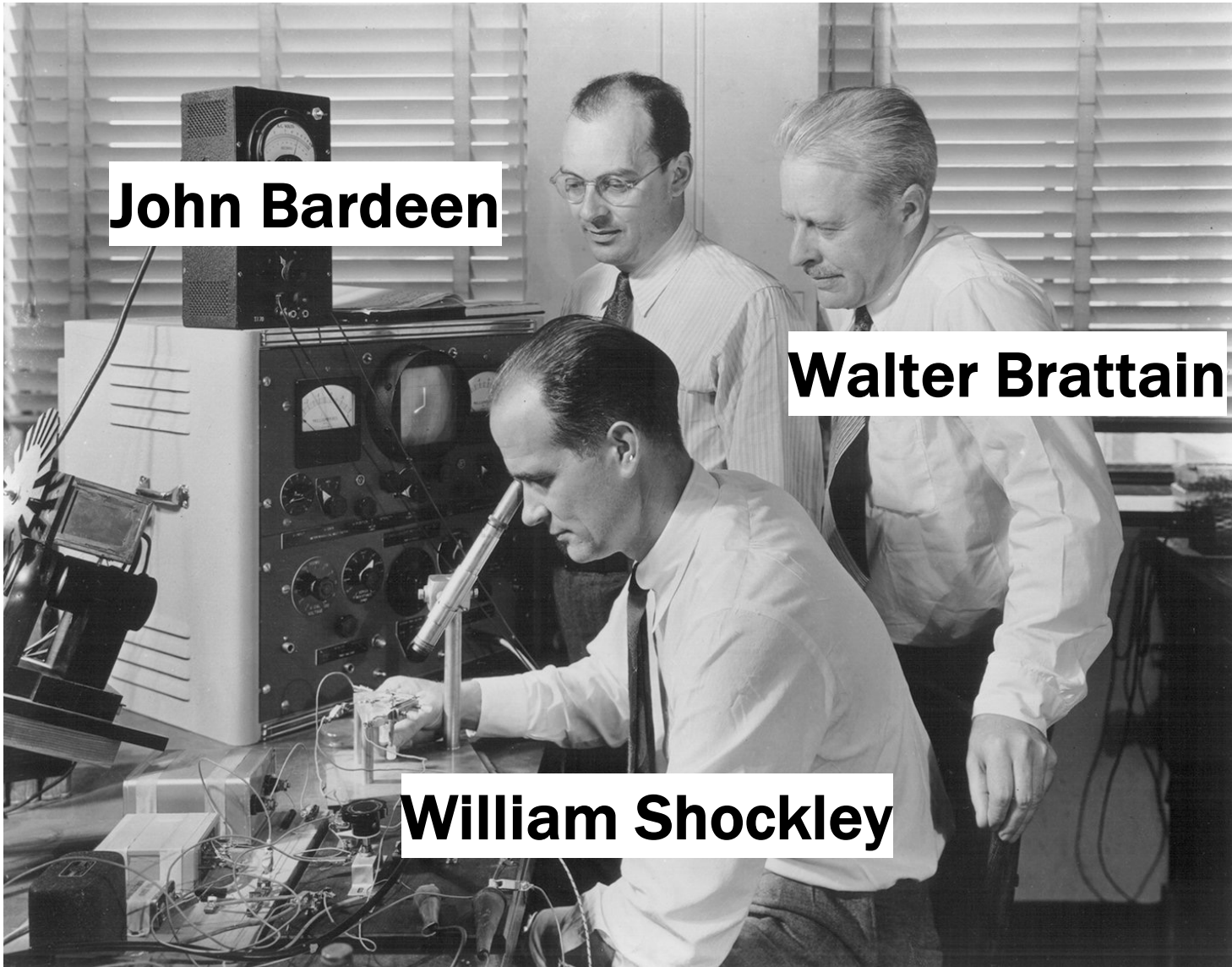

John Bardeen

Walter Brattain

William Shockley

THEY INVENTED THE TRANSISTOR



AND GOT A NOBEL PRIZE*

***IN PHYSICS**

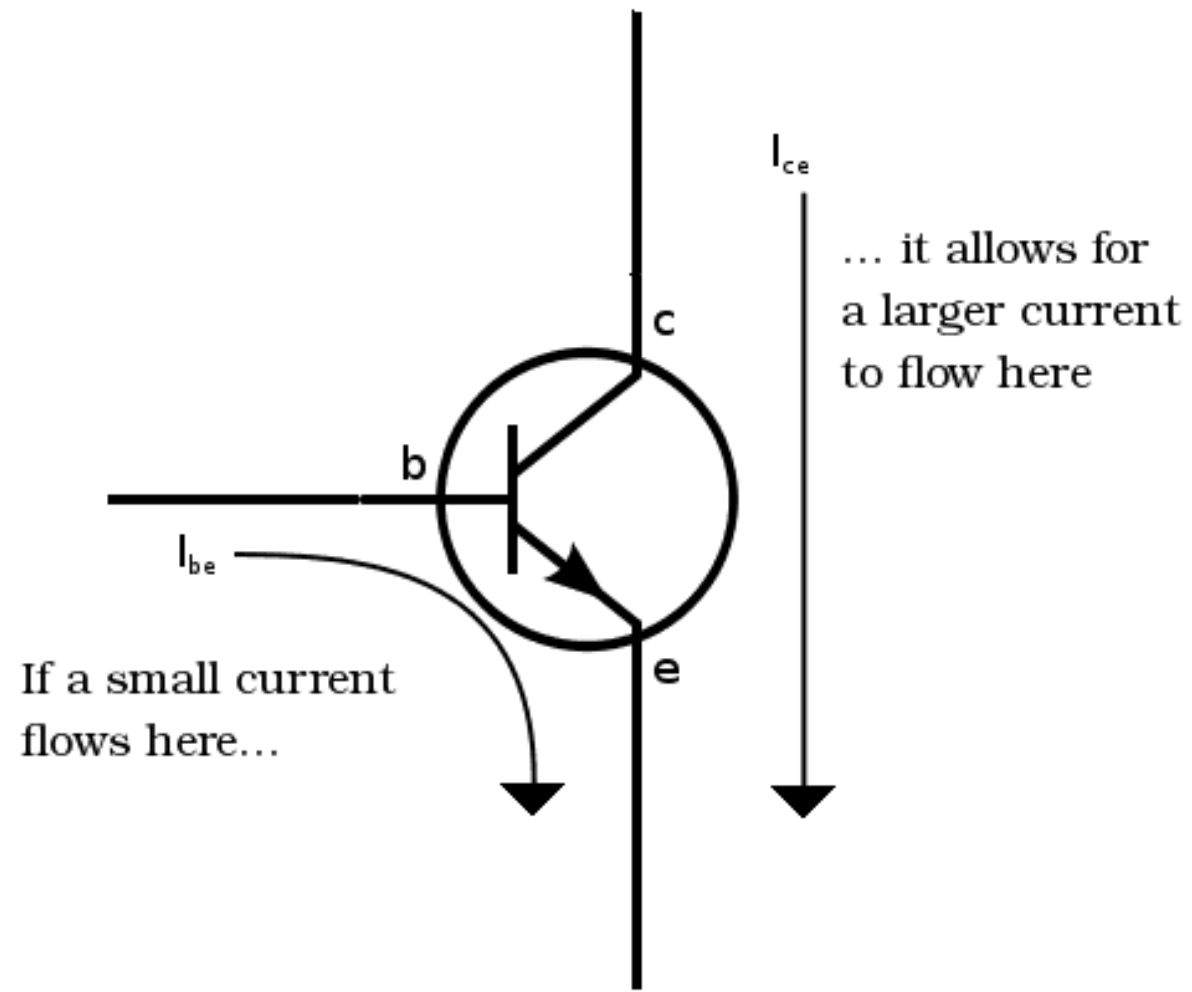

If a small current flows here...

... it allows for a larger current to flow here

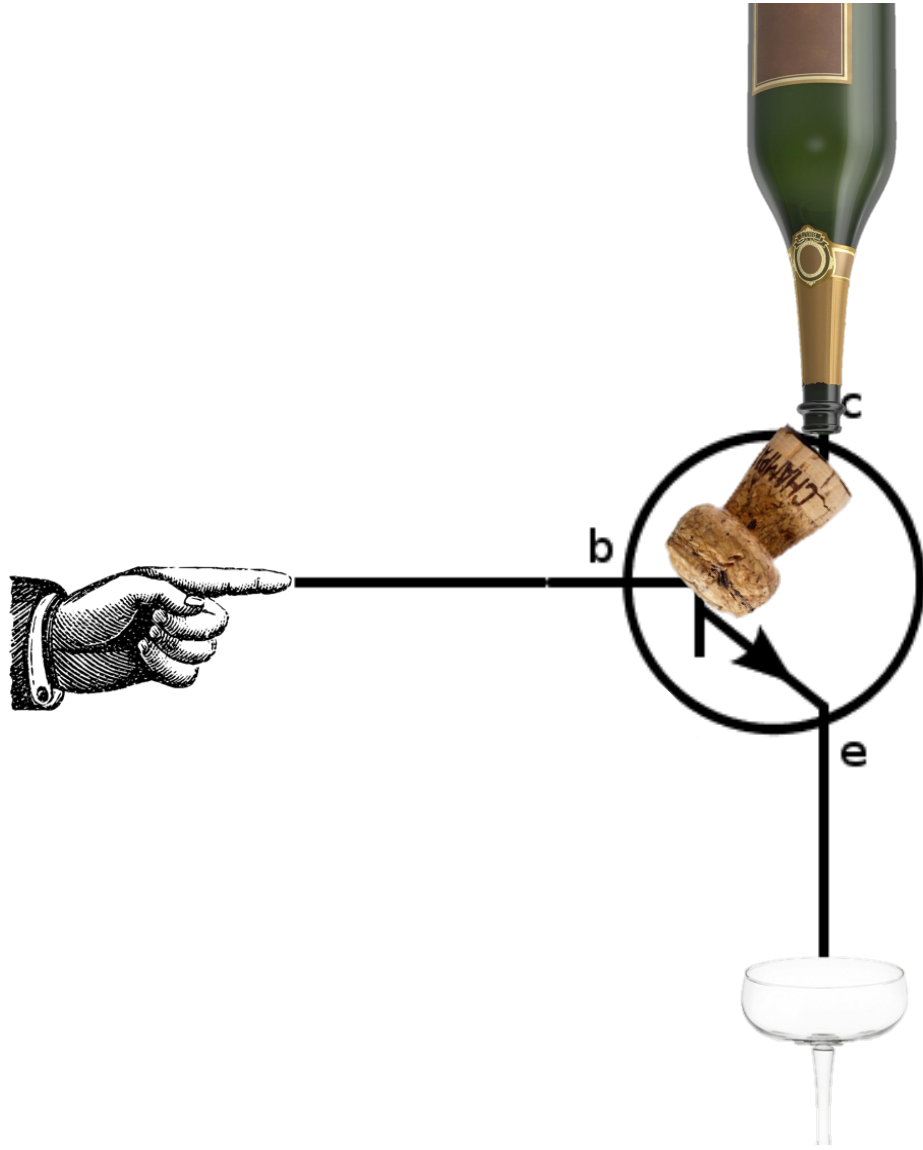

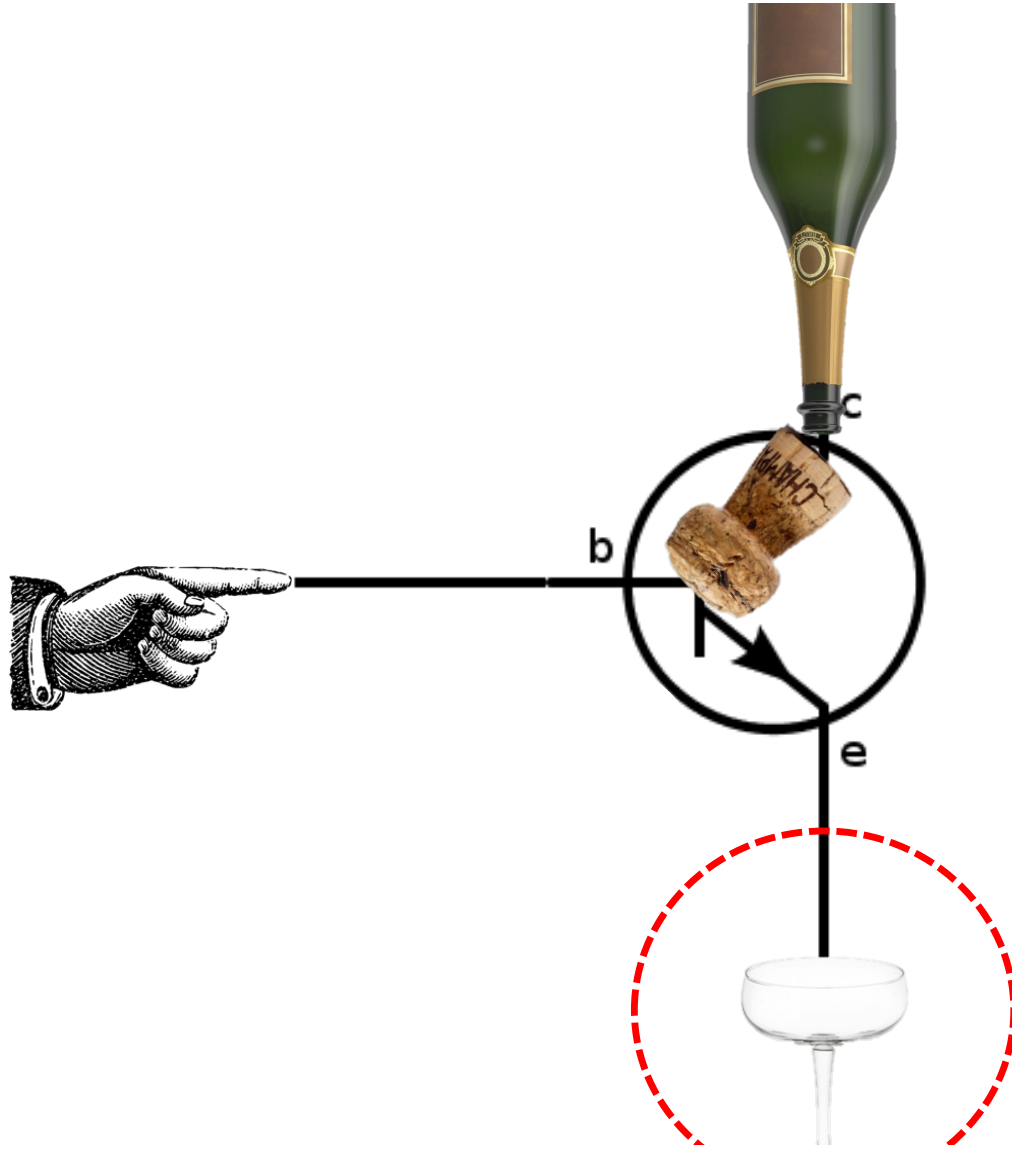



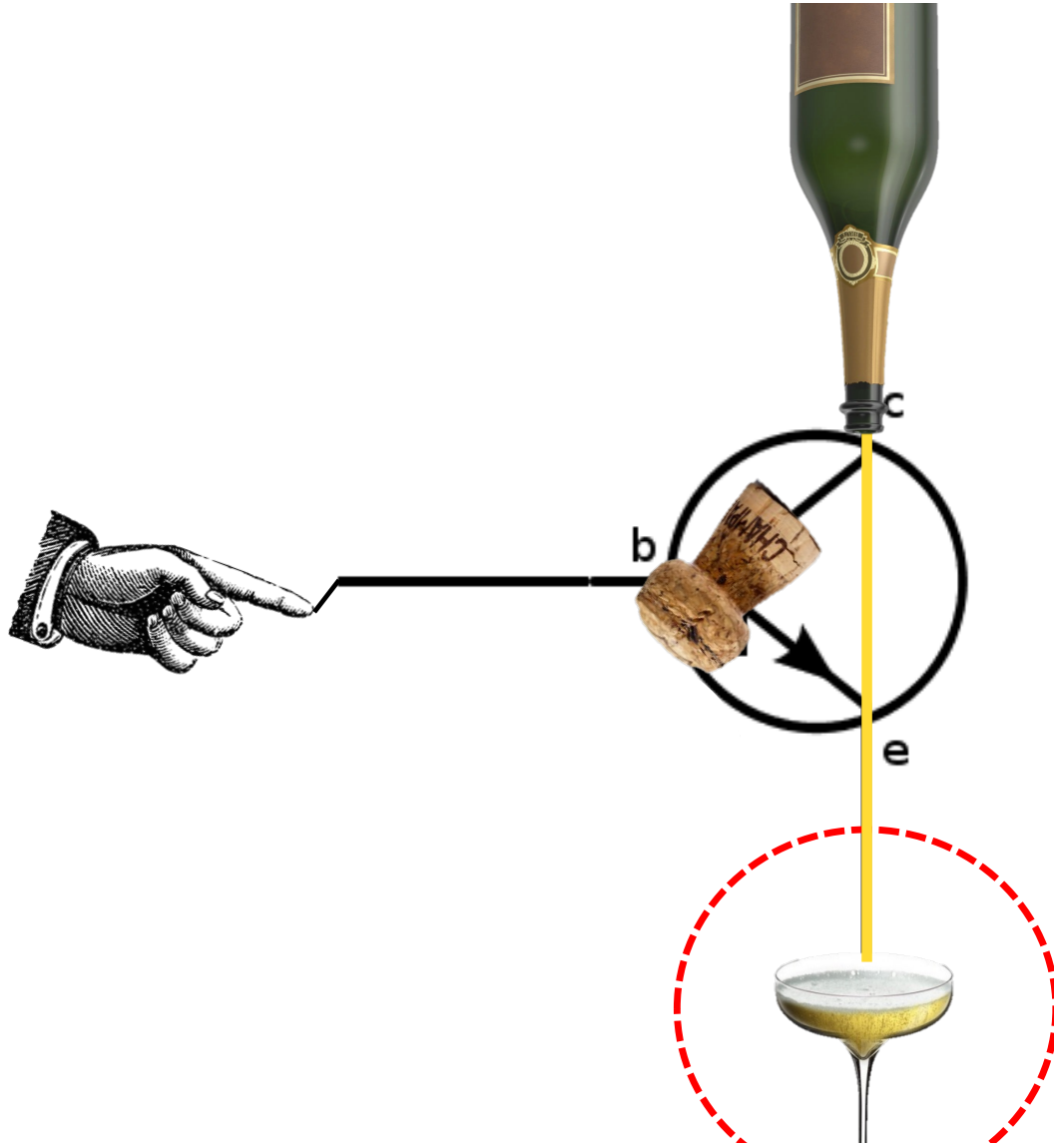

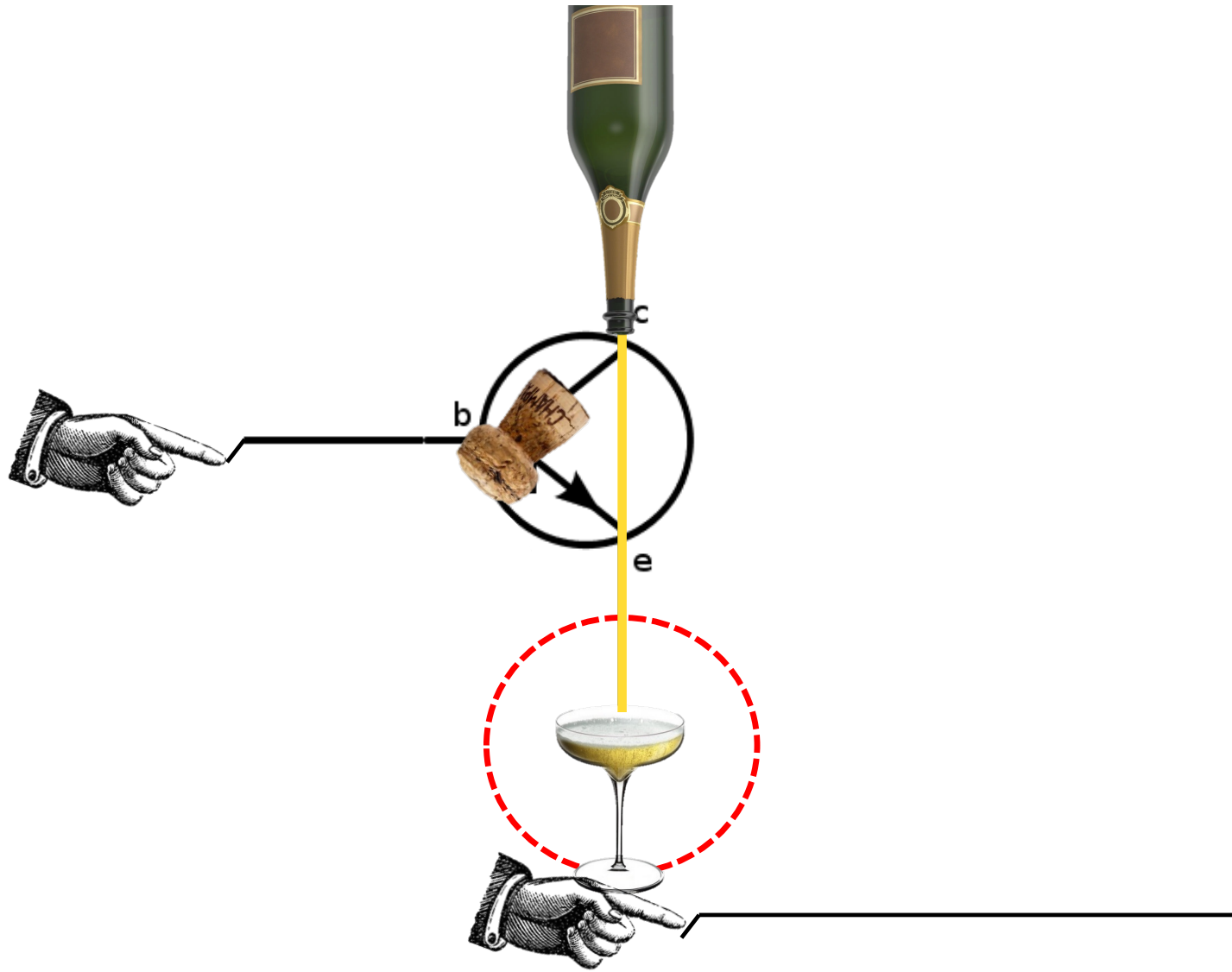

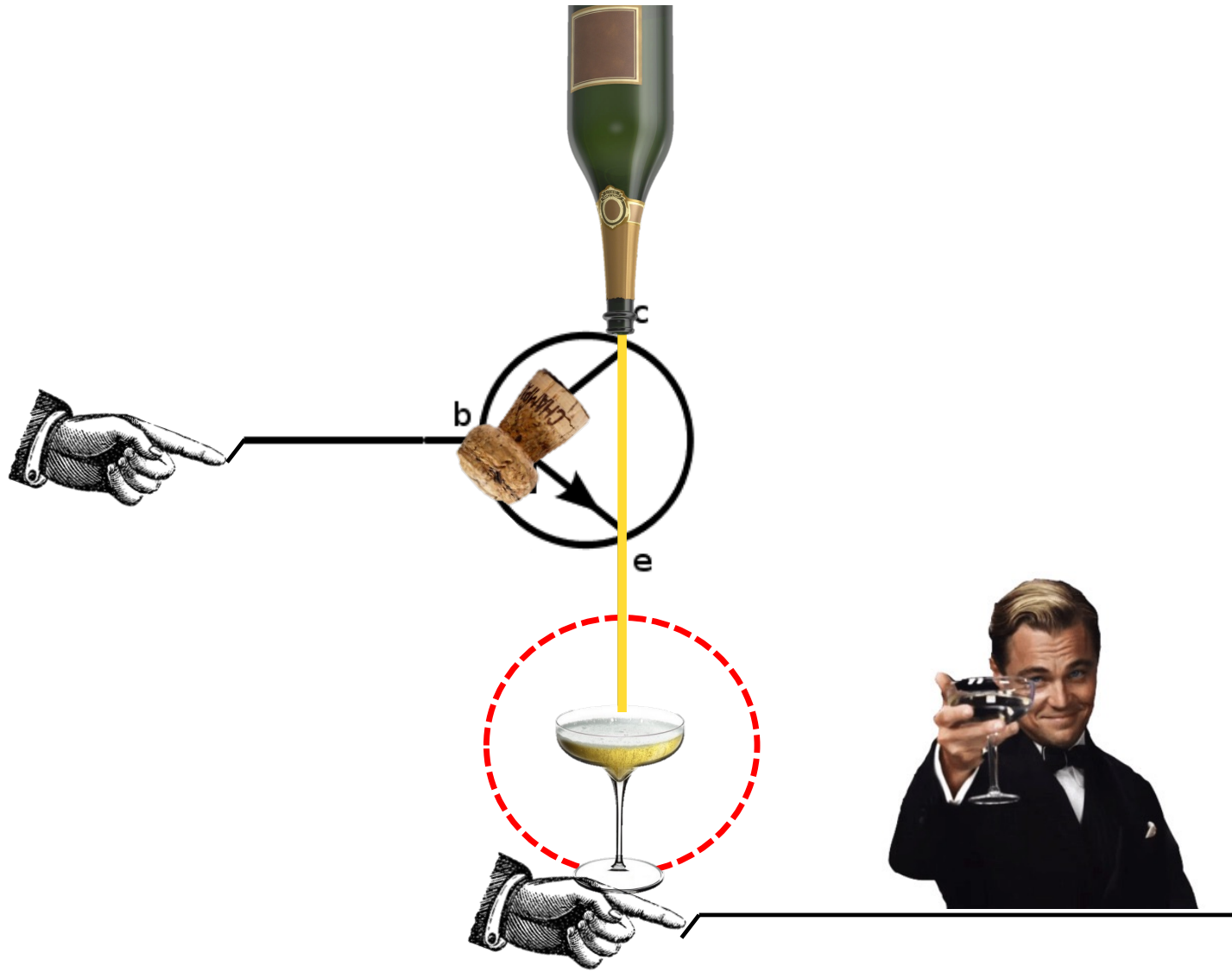

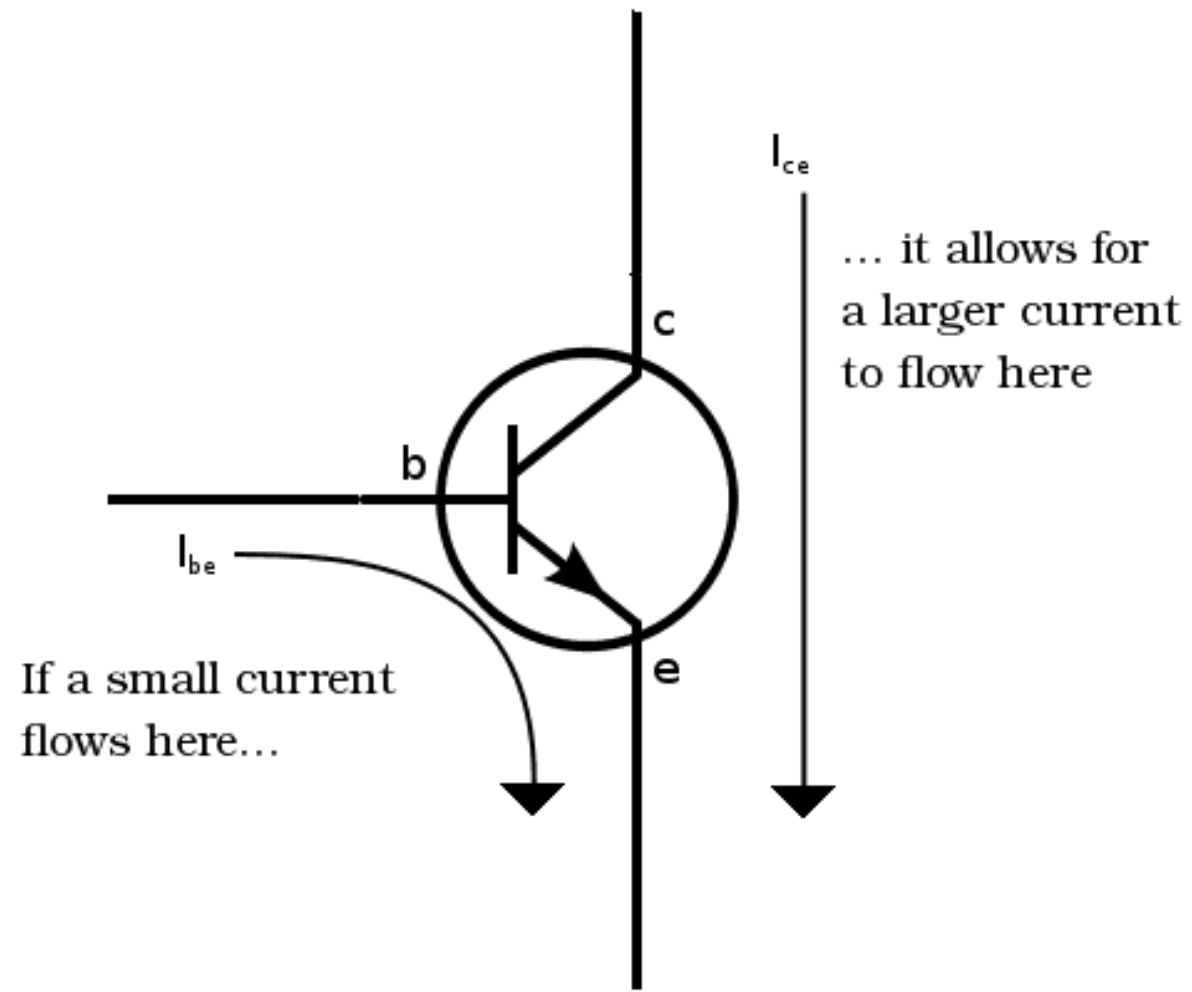

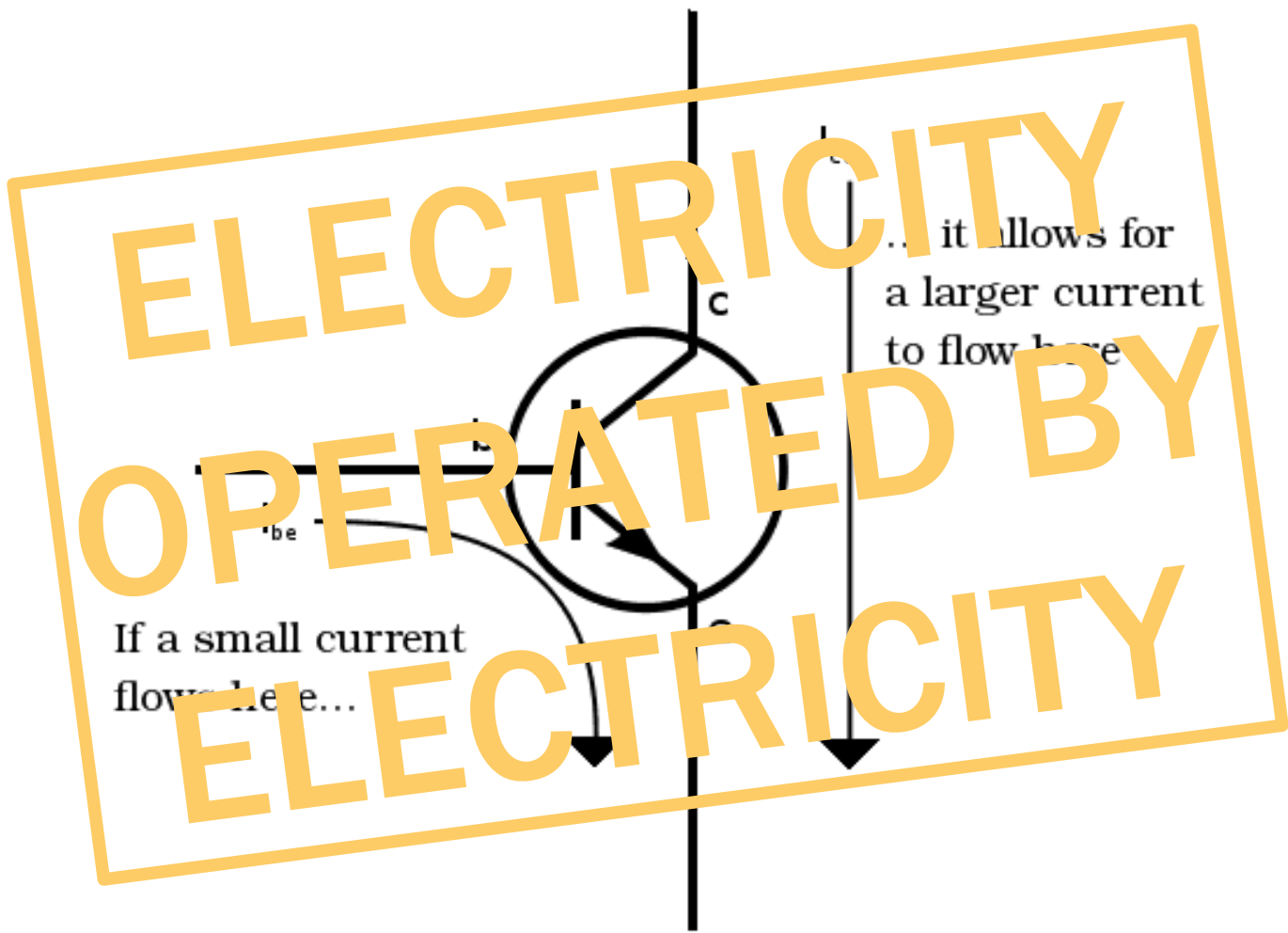

ELECTRICITY

OPERATED BY

ELECTRICITY

... it allows for a larger current to flow here

If a small current flows here...





**NO
MOVING
PARTS**

**HELLO
ELECTRONICS
GOODBYE
MECHANICS***

***Not really: I still need to grind my coffee beans. Also, flying.**



COMPUTERS DO NOT **NEED**
TO BE ELECTRONIC, BUT THEY ARE
BECAUSE EVERYBODY **LOVES TRANSISTORS**



**BOO
MECHANICS
BOOOO!**

M·G·M PRESENTS

FORBIDDEN PLANET

AMAZING!



STARRING WALTER PIDGEON · ANNE FRANCIS · LESLIE NIELSEN

WITH WARREN STEVENS AND INTRODUCING ROBBY, THE ROBOT
SCREEN PLAY BY CYRIL HUME
BASED ON A STORY BY IRVING BLOCK AND ALLEN ADLER

DIRECTED BY FRED McLEOD WILCOX · PRODUCED BY NICHOLAS NAYFACK
PHOTOGRAPHED IN EASTMAN COLOR
IN CINEMASCOPE AND COLOR

A METRO-GOLDWYN-MAYER PICTURE



BIG MACHINE.



NO INSTRUMENTALITIES.

Dubbed in Italian:

SENZA MECCANISMI.



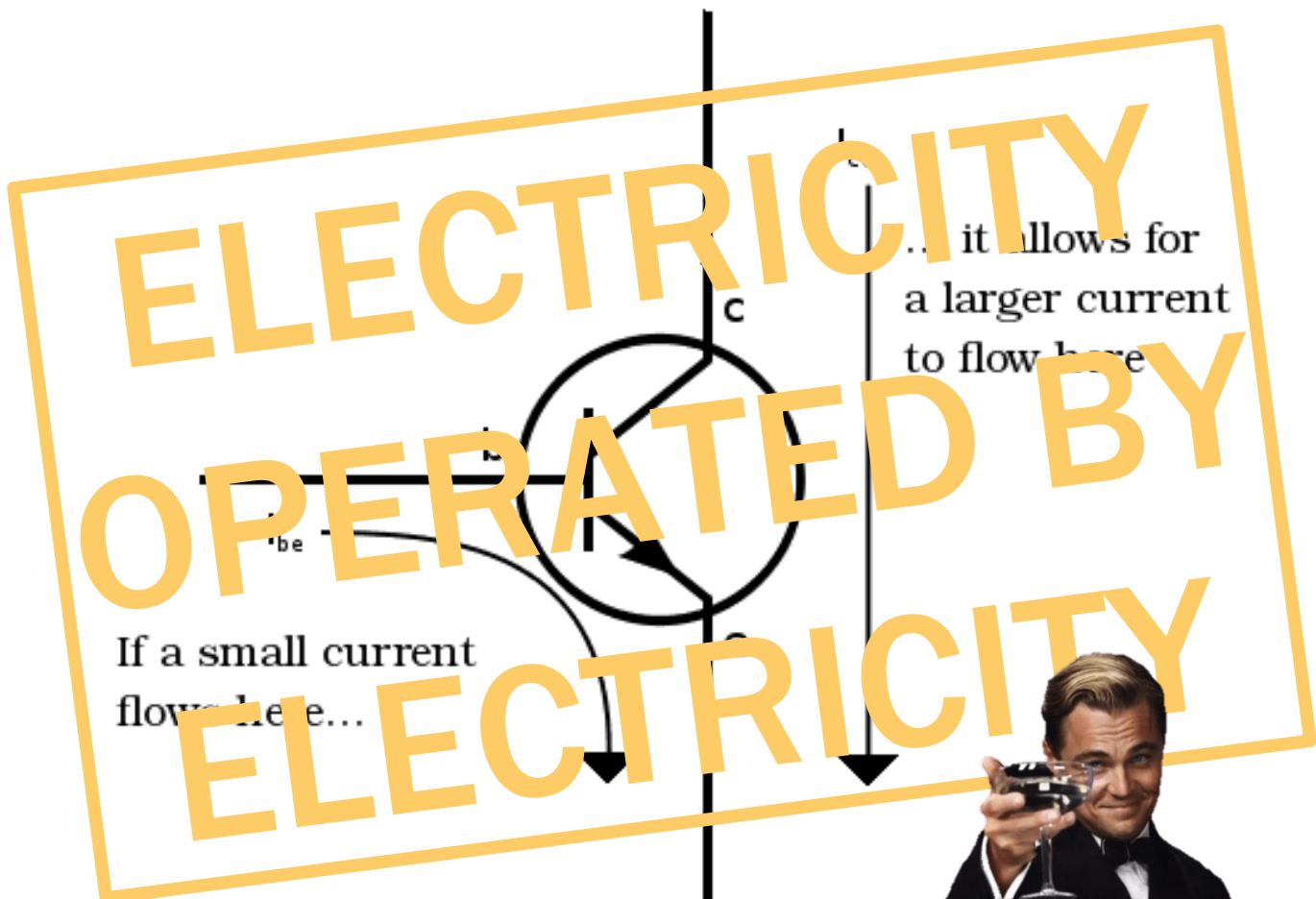

Dubbed in Italian:

SENZA MECCANISMI.







NO INSTRUMENTALITIES.



“FORBIDDEN PLANET”

FIRST MOVIE EVER to depict humans traveling in a faster-than-light starship of their own creation.

FIRST MOVIE EVER to be set entirely on another planet in interstellar space, far away from Earth.

FIRST MOVIE EVER to feature a robot character with a distinct personality and an integral supporting character in the film.

FIRST MOVIE EVER to use an entirely ELECTRONIC musical score.

M·G·M PRESENTS

FORBIDDEN PLANET

AMAZING!



STARRING WALTER PIDGEON · ANNE FRANCIS · LESLIE NIELSEN
WITH WARREN STEVENS AND INTRODUCING ROBBY, THE ROBOT
DIRECTED BY FRED McLEOD WILCOX · PRODUCED BY NICHOLAS NAYFACK
SCREEN PLAY BY CYRIL HUME
BASED ON A STORY BY IRVING BLOCK AND ALLEN ADLER
PHOTOGRAPHED IN EASTMAN COLOR
IN CINEMASCOPE AND COLOR
A METRO-GOLDWYN-MAYER PICTURE

M·G·M PRESENTS

FORBIDDEN PLANET

AMAZING!



1956

STARRING WALTER PIDGEON · ANNE FRANCIS · LESLIE NIELSEN

WITH WARREN STEVENS AND INTRODUCING ROBBY, THE ROBOT SCREEN PLAY BY CYRIL HUME BASED ON A STORY BY IRVING BLOCK AND ALLEN ADLER

DIRECTED BY FRED McLEOD WILCOX · PRODUCED BY NICHOLAS NAYFACK IN CINEMASCOPE AND COLOR PHOTOGRAPHED IN EASTMAN COLOR

A METRO-GOLDWYN-MAKER PICTURE

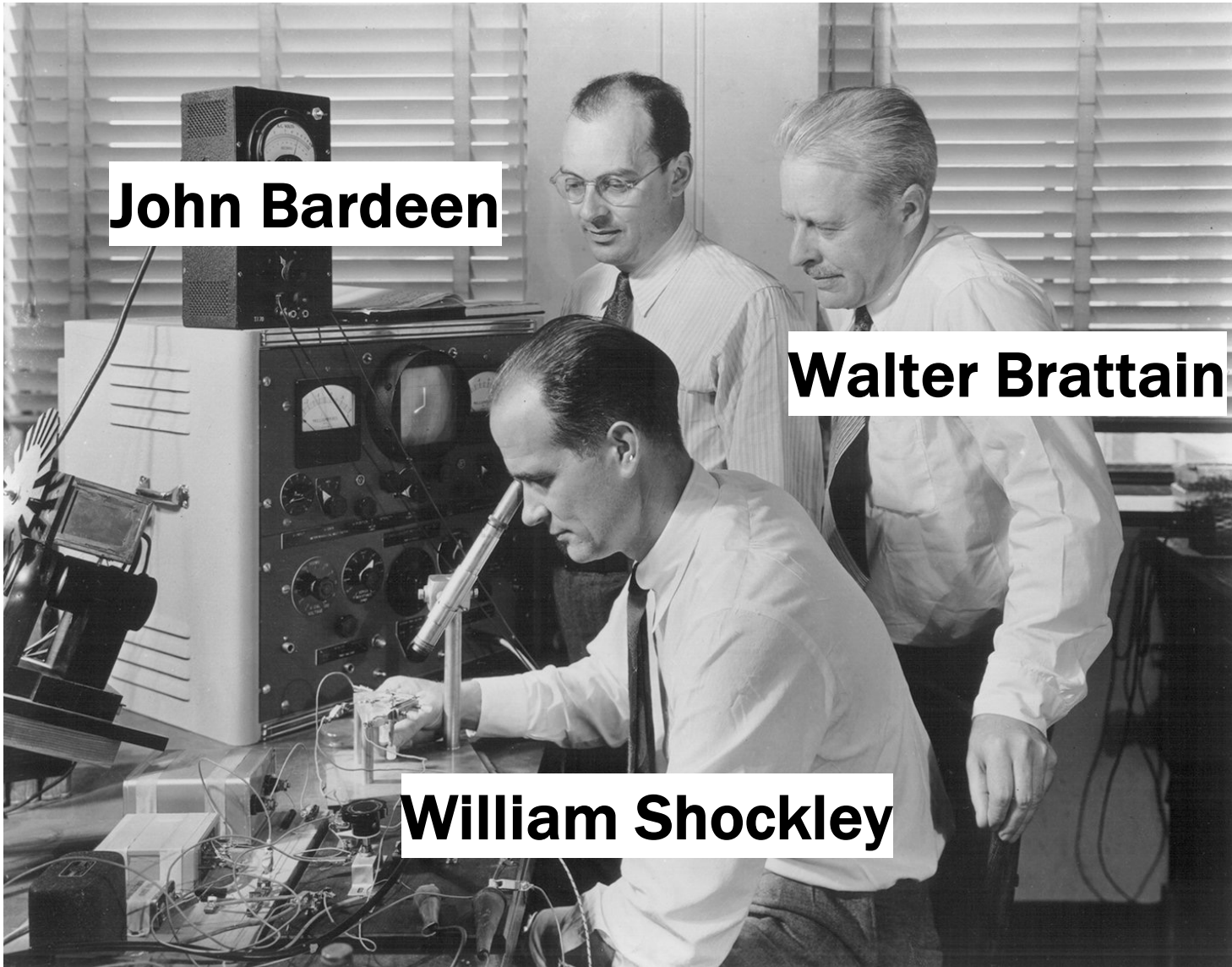

John Bardeen

Walter Brattain

William Shockley

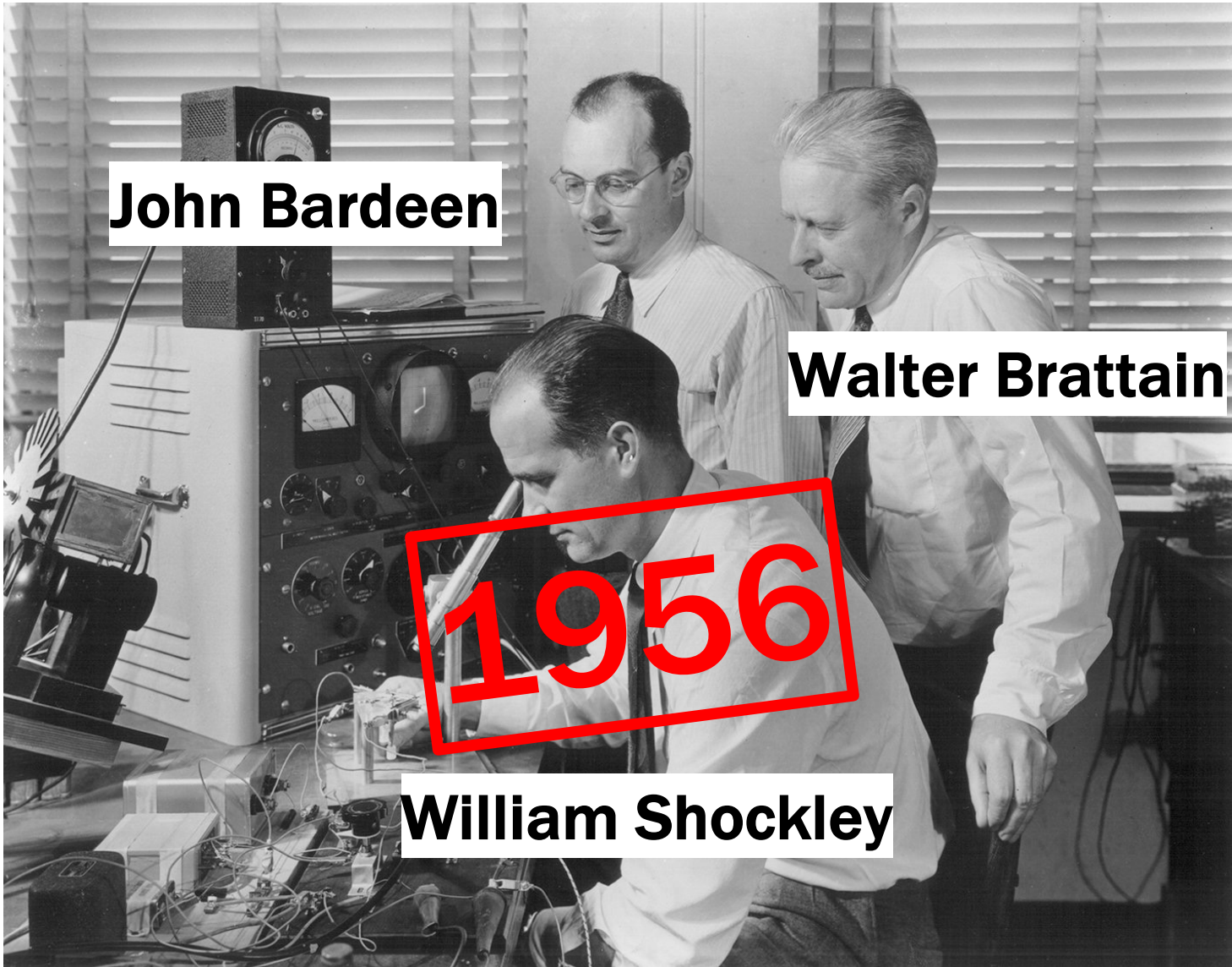

John Bardeen

Walter Brattain

1956

William Shockley



WAIT!

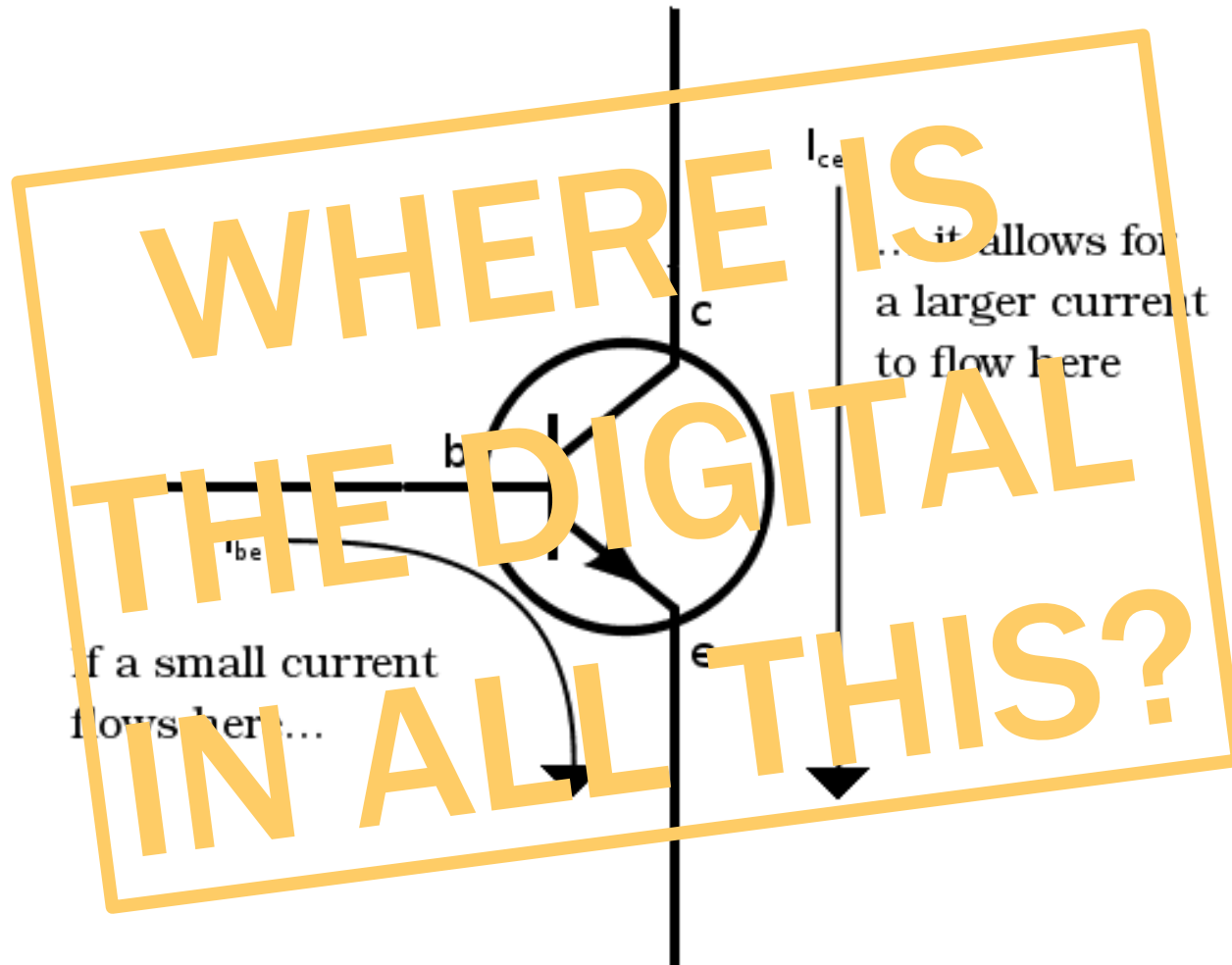

**THE MOST
FUNDAMENTAL
ENCODING
OF THEM ALL***

***No side notes here. It really is the most fundamental.**





0



1

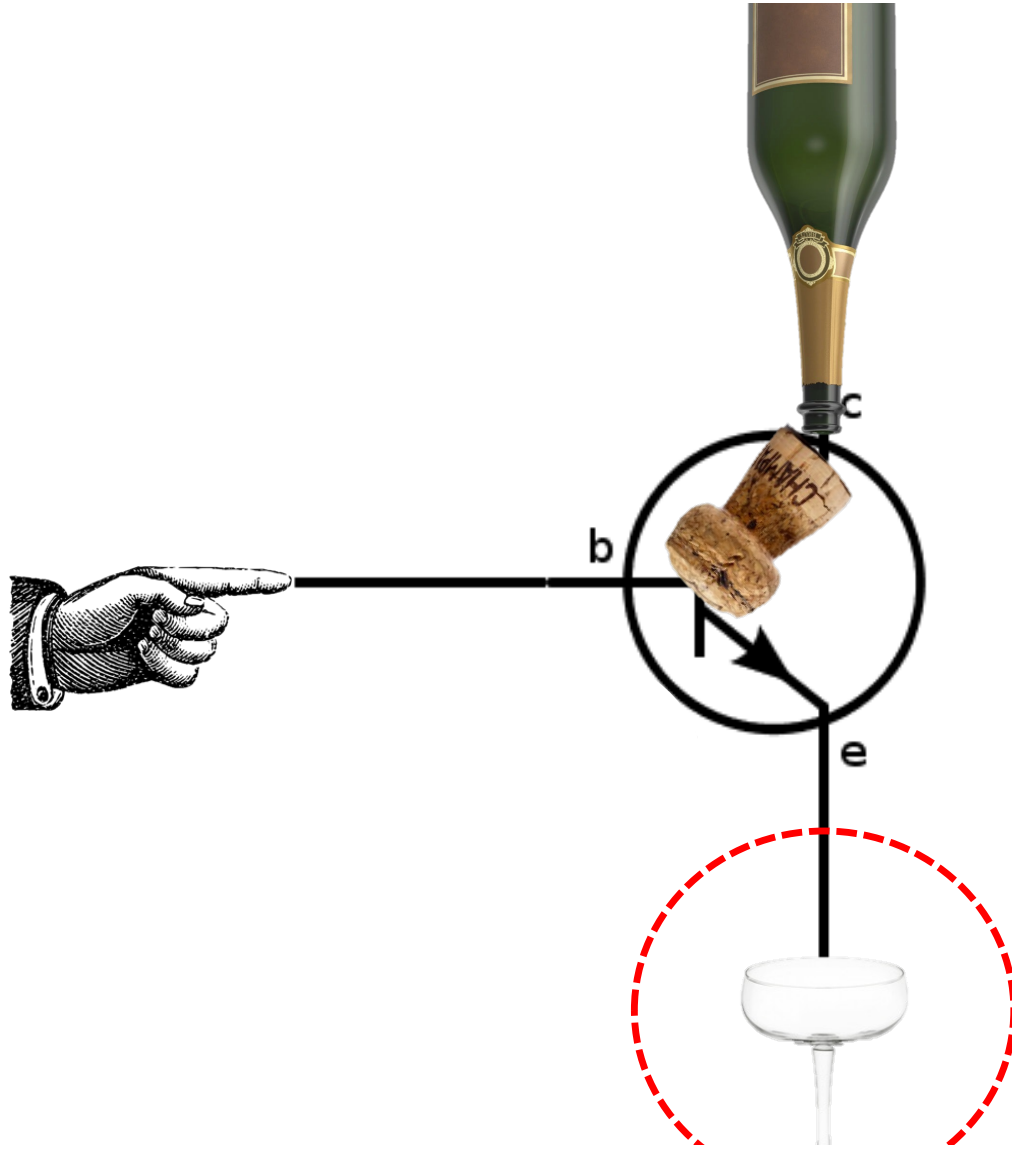

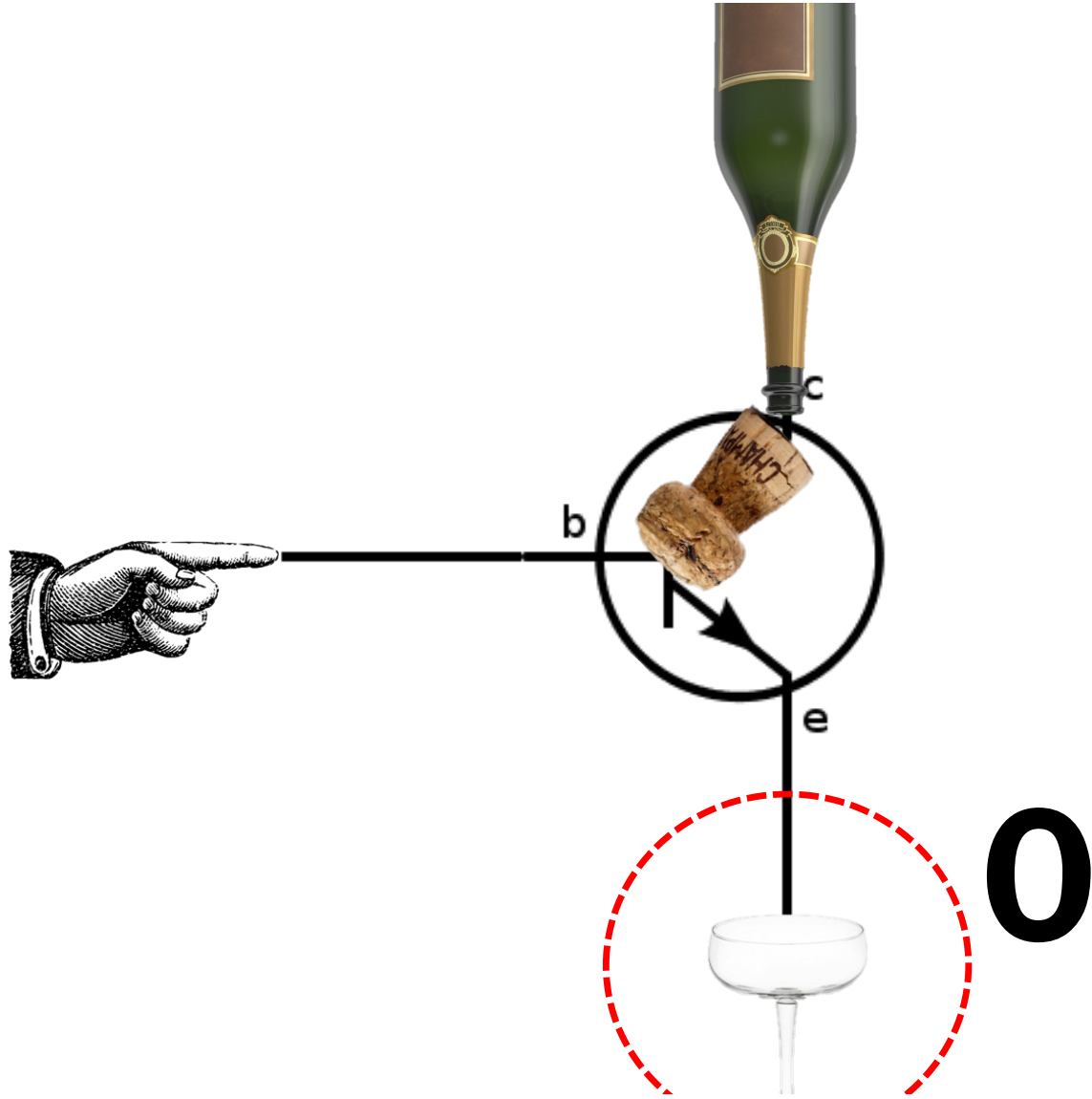

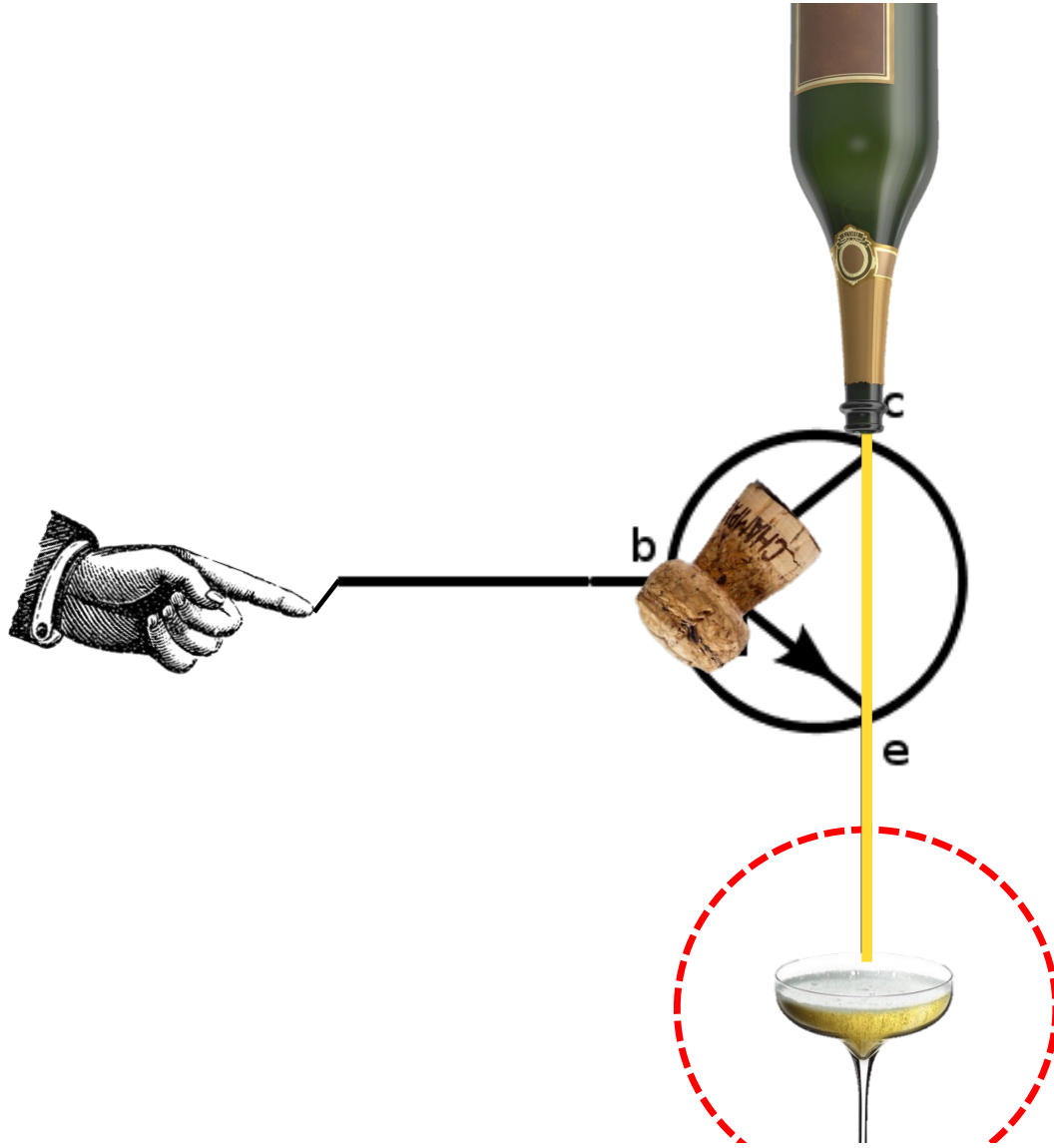

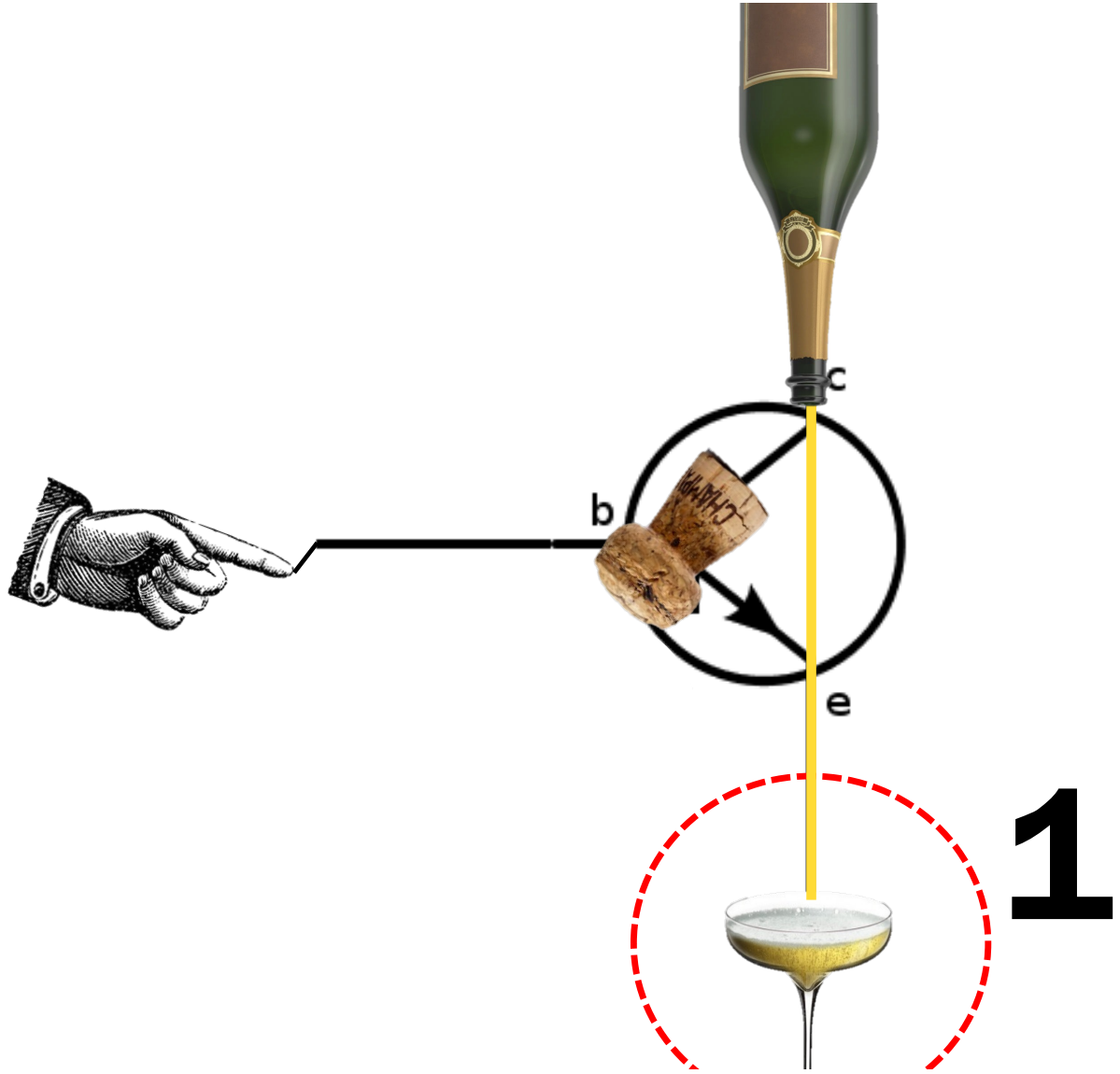

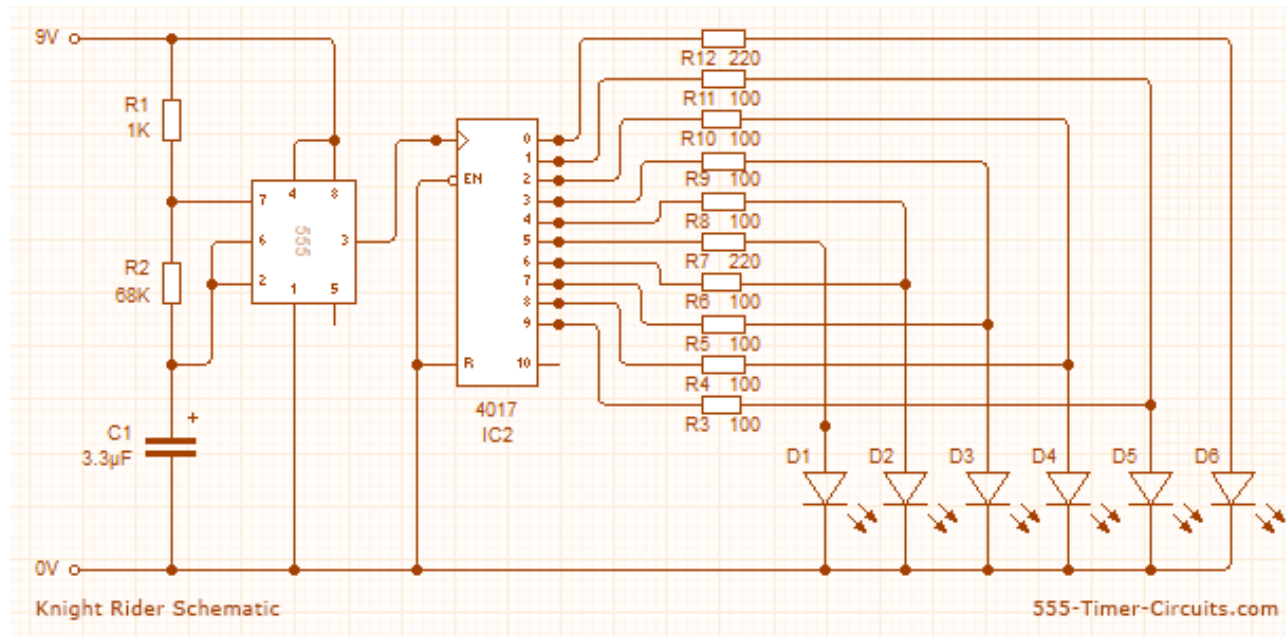

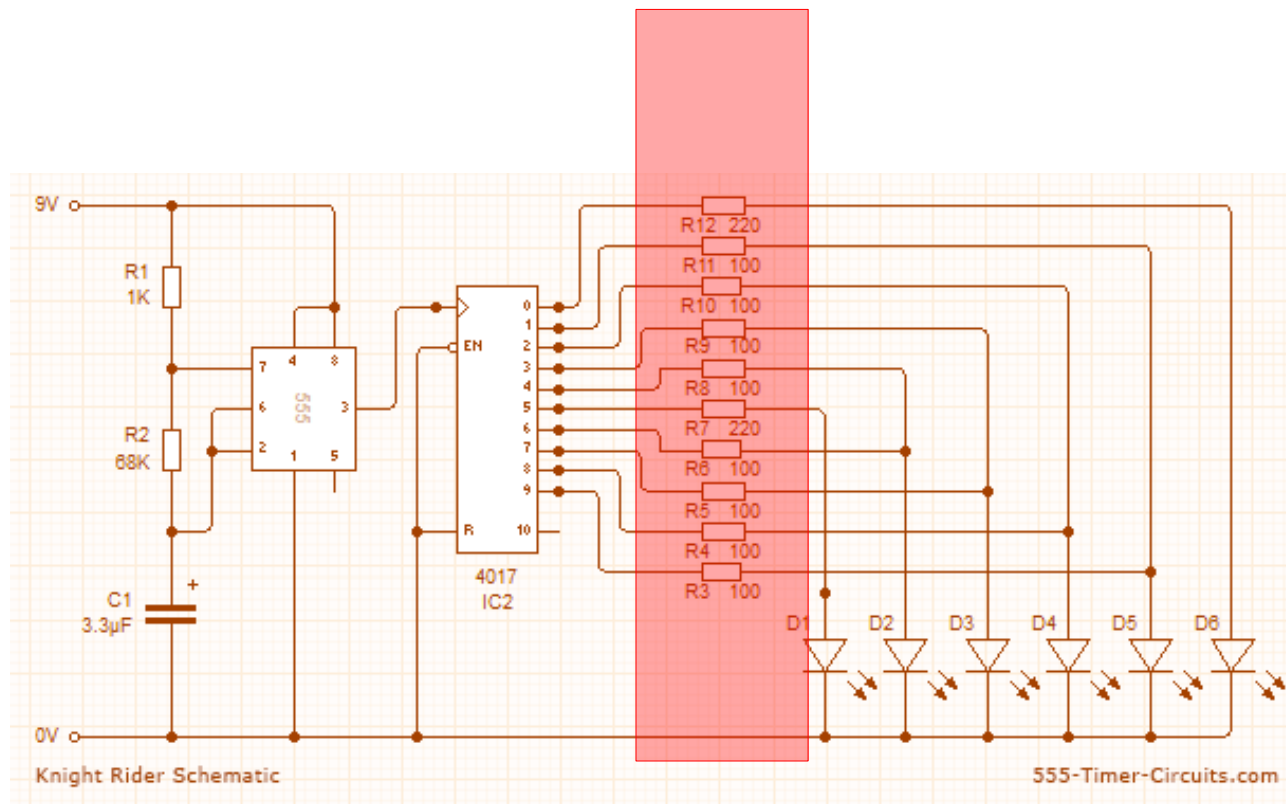

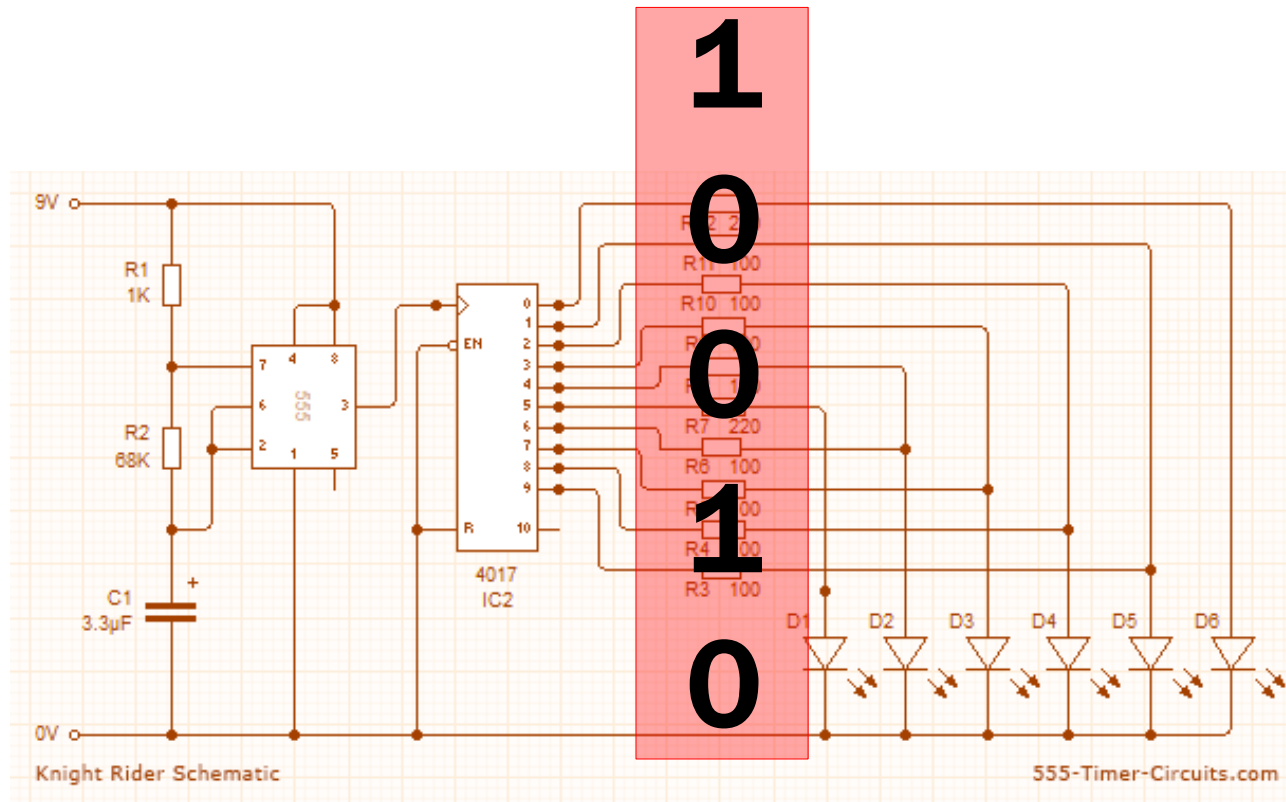

**ARE THE
DIGITS
REALLY
THERE?**



**DIGITS ARE IN THE
EYE OF THE BEHOLDER.**



WAIT!

01234567890123456
123456789012345678
234567890123456789
345678901234567890
123456789012345678
234567890123456789
34567890123456789
4567890123456789

I promised you this.

01111000101010101
10101110101010101;
0110101110101010
11011101010101010
10101110001010101
11101011101010110
10011011100001110
11101010101111010

I am giving you this.

01111000101010101
10101110101010101:
0110101110101010
11011101010101010
10101110001010101
11101011101010110
1001111111111010
11101010101111010r

I am giving you this.

Did I lie to you?

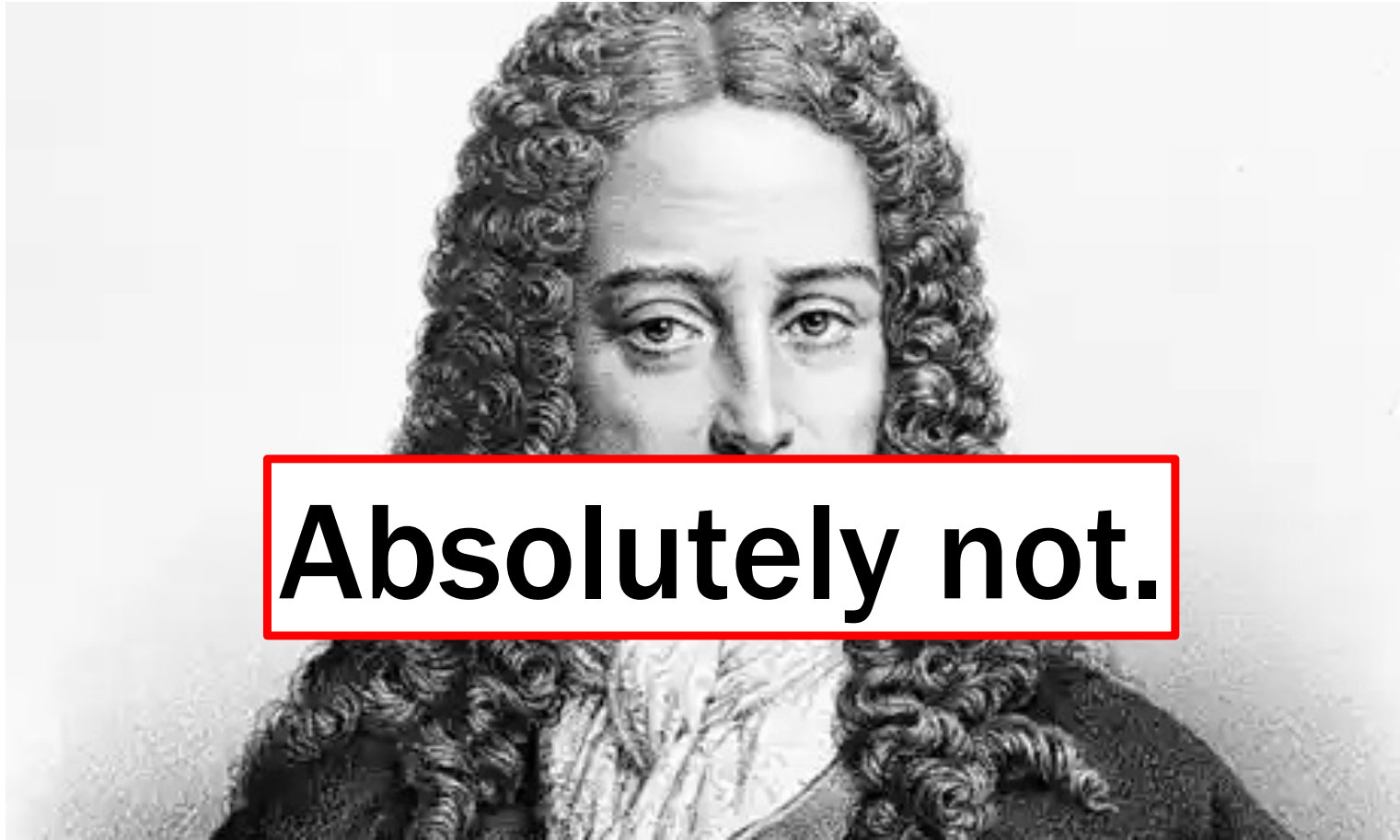

Absolutely not.



**Gottfried Wilhelm Leibniz
(1646-1716)**

THE BINARY SYSTEM {0;1}

THE DECIMAL SYSTEM

{0;1;2;3;4;
5;6;7;8;9}

237

237

2

1

0

$2 \times 10^2 = 200$

$7 \times 10^0 = 7$

$3 \times 10^1 = 30$

THE BINARY SYSTEM {0;1}

101

2 1 0

$$1 \times 2^2 = 4$$

$$1 \times 2^0 = 1$$

$$0 \times 2^1 = 0$$

101

in binary

encodes

the number 5

101₂

=

5₁₀

237

2

1

0

$2 \times 10^2 = 200$

$7 \times 10^0 = 7$

$3 \times 10^1 = 30$

**What is the
binary encoding
of 237?**

$$237 =$$

$$128 + 64 + 32$$

$$+ 8 + 4 + 1$$

(look for powers of 2)

$$237 =$$

$$2^7 + 2^6 + 2^5$$

$$+ 2^3 + 2^2 + 2^0$$

$$237 =$$

$$2^7 + 2^6 + 2^5$$

$$+ 2^3 + 2^2 + 2^0$$

(put a 1 in the positions
indicated by the exponents,
0 in the other positions)

11101101

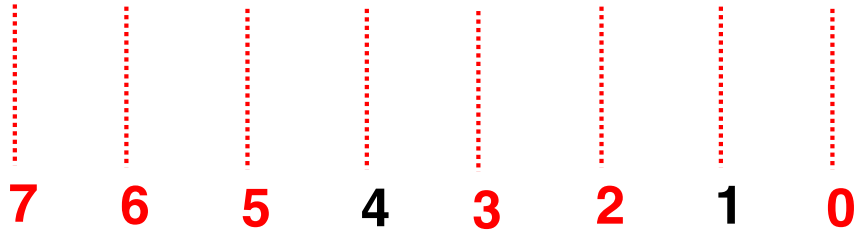

11101101₂

=

237₁₀

01234567890123456
123456789012345678
234567890123456789
345678901234567890
1234567890123456789
2345678901234567890
345678901234567890
45678901234567890

No need for this.

01111000101010101
10101110101010101;
0110101110101010
11011101010101010
10101110001010101
11101011101010110
10011011100001110
1110101011111010r

This will do just fine.

BIBLIOGRAPHY

- ▶ Verdicchio M., *L'informatica per la comunicazione*, Franco Angeli, Milano, 2015 (seconda edizione)
- ▶ Verdicchio M., The digital in digital art, *Studi di estetica*, anno XLVI, IV serie, 3/2018
- ▶ Girelli L., *Noi e i numeri*, Il Mulino, Bologna, 2006
- ▶ Bottazioni U., *Numeri. Raccontare la matematica*,
- ▶ Valerio C., *Storia umana della Matematica*, Einaudi, Torino, 2016 (ebook ISBN 9788858423721)
- ▶ Burdick A., Drucker J., Lunefeld P. Presner T., Shnapp J., *Umanistica _ Digitale*, Mondadori, Milano, 2015 (trad.it Burdick A., Drucker J., Lunefeld P. Presner T., Shnapp J., *Digital_Humanities*, MIT Press, Cambridge, MA), 2012

WEBGRAPHY

- ▶ Chiara Valerio, Dialoghi su tecnologia, matematica e politica (2020?), <https://www.youtube.com/watch?v=L-UUXhjvlnQ>; 18 febbraio 2022